

MC150

POWER AMPLIFIER

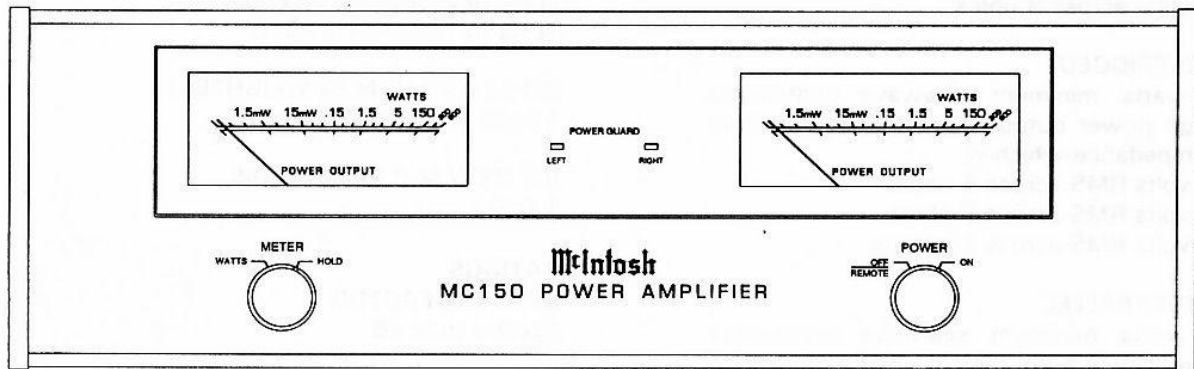

CONTENTS

Performance Specifications	2	◇ Right Front Panel Illumination	13
Rear Panel	3	◇ Left Meter Illumination	14
Front Panel & Trim Parts List	3	◇ Right Meter Illumination	14
Notes	3	◇ Power Guard Illumination	14
Section Locations	4	◇ Meter/Regulator	15-17
Block Diagram	5-6	◇ Amplifier	18-23
◇ Interconnection Diagram	7-10	◇ Relay	24-26
◇ Input	11-12	Repacking Instructions	27
◇ Left Front Panel Illumination	13		

McIntosh

Service Manual

Performance Specifications

POWER OUTPUT

Stereo

150 watts minimum sine wave continuous average power output, per channel, both channels operating into 2 ohms, 4 ohms or 8 ohms load impedance.

17.3 volts RMS across 2 ohms

24.5 volts RMS across 4 ohms

34.6 volts across 8 ohms

MONO/BRIDGED

300 watts minimum sinewave continuous average power output into 4, 8 or 16 ohms load impedance which is

34.6 volts RMS across 4 ohms

49.0 volts RMS across 8 ohms

69.3 volts RMS across 16 ohms

MONO/PARALLEL

300 watts minimum sinewave continuous average power output into 1, 2 or 4 ohms load impedance which is

17.3 volts RMS across 1 ohm

24.5 volts RMS across 2 ohms

34.6 volts RMS across 4 ohms

OUTPUT LOAD IMPEDANCE

Stereo

2 ohms, 4 ohms, and 8 ohms; separate terminals are provided for each output.

OUTPUT LOAD IMPEDANCE

Mono/Bridged

4 ohms, 8 ohms or 16 ohms by connecting to the proper output terminals.

Mono/Parallel

1 ohm, 2 ohms or 4 ohms by connecting to the proper output terminals.

RATED POWER BAND

20Hz to 20,000Hz

TOTAL HARMONIC DISTORTION

0.005% Maximum harmonic distortion at any power level from 250 milliwatts to 150 watts per channel from 20Hz to 20,000Hz, both channels operating.

INTERMODULATION DISTORTION

0.005% maximum harmonic if instantaneous peak power output is 300 watts or less per channel with both channels operating for any combination of frequencies, 20Hz to 20,000Hz.

FREQUENCY RESPONSE (AT ONE WATT OUTPUT)

20Hz to 20,000Hz -0.25dB

10Hz to 100,000Hz -3dB

NOISE AND HUM (A-WEIGHTED)

110dB below rated output

IHF DYNAMIC HEADROOM

1.8dB

RATINGS

DAMPING FACTOR

Greater than 40

INPUT IMPEDANCE

20,000 ohms

INPUT SENSITIVITY

1.4 volts, level control provides for higher input voltages; 2.5 volt position at detent.

POWER GUARD

Clipping is prevented and THD does not exceed 2% with up to 14dB overdrive at 1kHz.

POWER REQUIREMENTS

120VAC, 50/60Hz, 3.3 Amperes UL/CSA

230VAC, 50/60Hz, 1.8 Amperes

MECHANICAL INFORMATION

Size: Front panel measures 17-1/2 inches (44.5cm) wide, by 5-3/8" (13.7cm) high. Depth behind mounting panel including clearance for connectors, 19-3/4 inches (50.2cm). Knob clearance required in front of the mounting panel, 1-1/8 inches (2.9cm).

Weight: 59 pounds (26.8kg) net, 76 pounds (34.5kg) in shipping carton.

Rear Panel

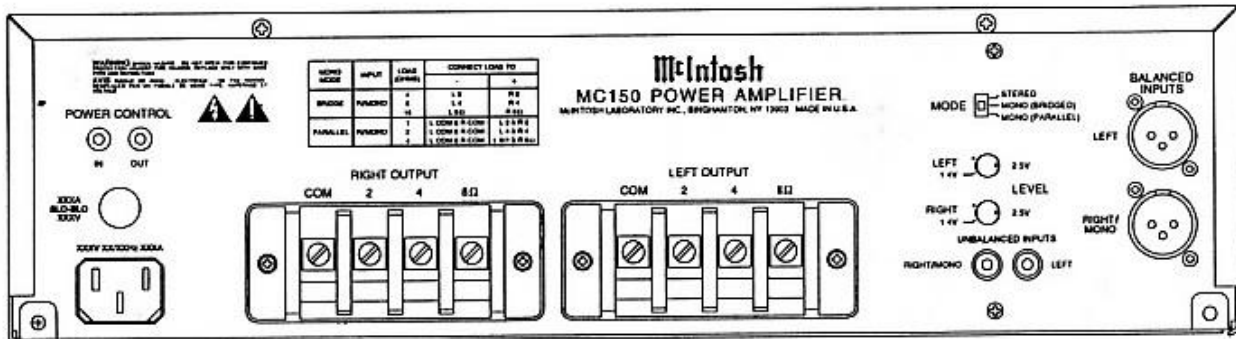



Fig. 1 - Rear view

FRONT PANEL and TRIM PARTS LIST

Part	Description
018232	End Caps
018451	Bottom Panel Extrusion
018453	Top Panel Extrusion
048696	Front Panel, Complete
090212	Control Knob Serial Nos. LM1001 thru LM1420
090215	Control Knob Serial Nos. LM1421 and Above
104017	Knob Felt Washer, 3/4" Dia

Notes

- The heavy lines on the schematics denote the primary signal path.
- Unless otherwise noted, all voltages indicated on the schematics are measured under the following conditions:
 - AC input at 120 volts, 50/60Hz.
 - All voltages are $\pm 10\%$ with respect to ground. A high impedance (10 megohm) voltmeter must be used.
- Unless otherwise specified:
 - Resistor values are in ohms.
 - Capacitor values are in microfarads (μF).
 - Inductor values are in microhenries (μH).
- The voltages enclosed in a box are signal voltages that are measured with a 1.4V, 1kHz signal connected to both channels at the input jacks.
- On PC Board Drawings, Square Pad Indicates:
 - Polarized Capacitors - Positive
 - Diode - Cathode
 - Others - Pin 1
- WARNING:** Parts marked with the symbol  have critical characteristics. Use **ONLY** replacement parts recommended by the manufacturer.

Front panel controls are set at:
 POWER ON
 METER WATTS

Section Locations

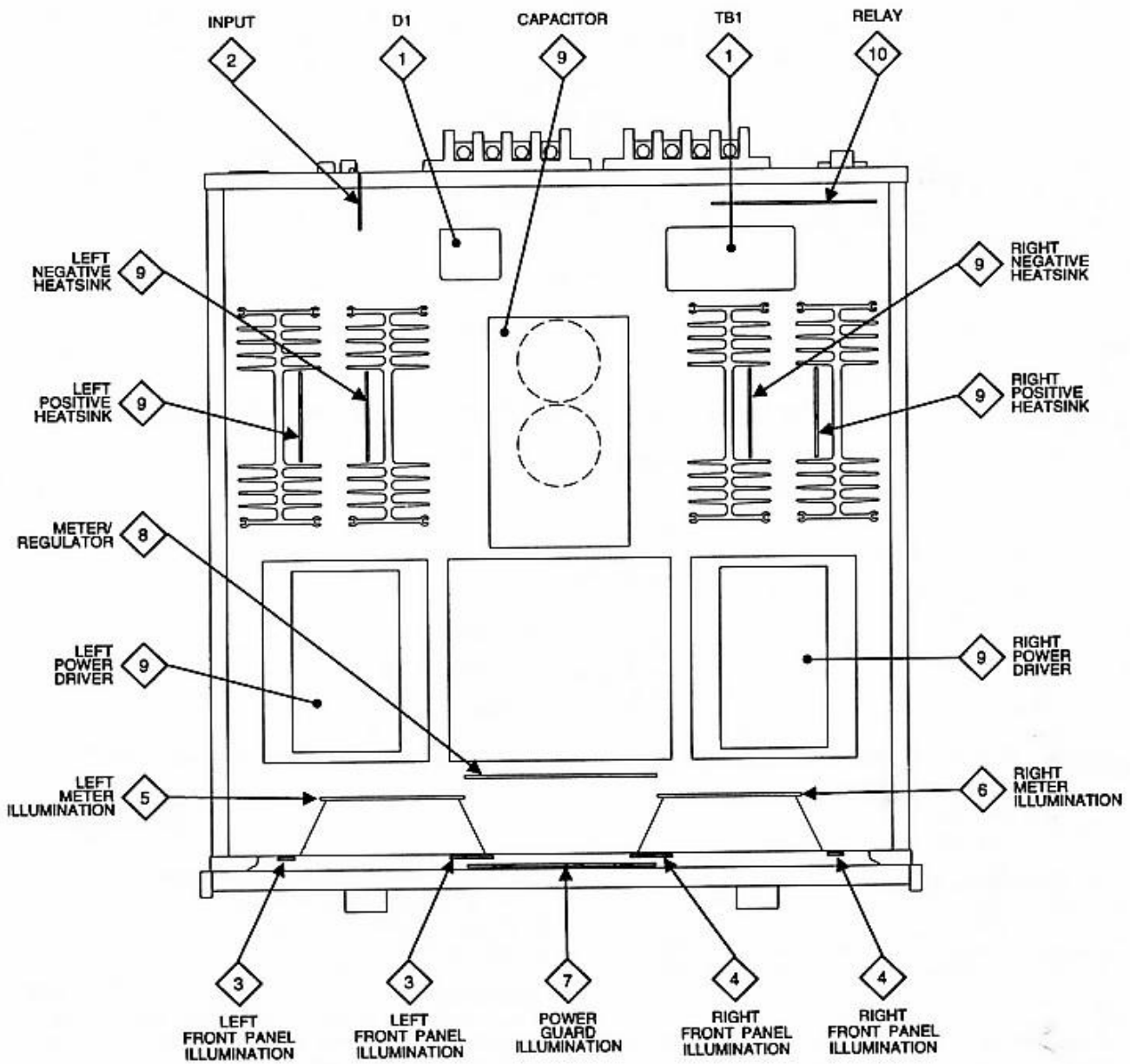
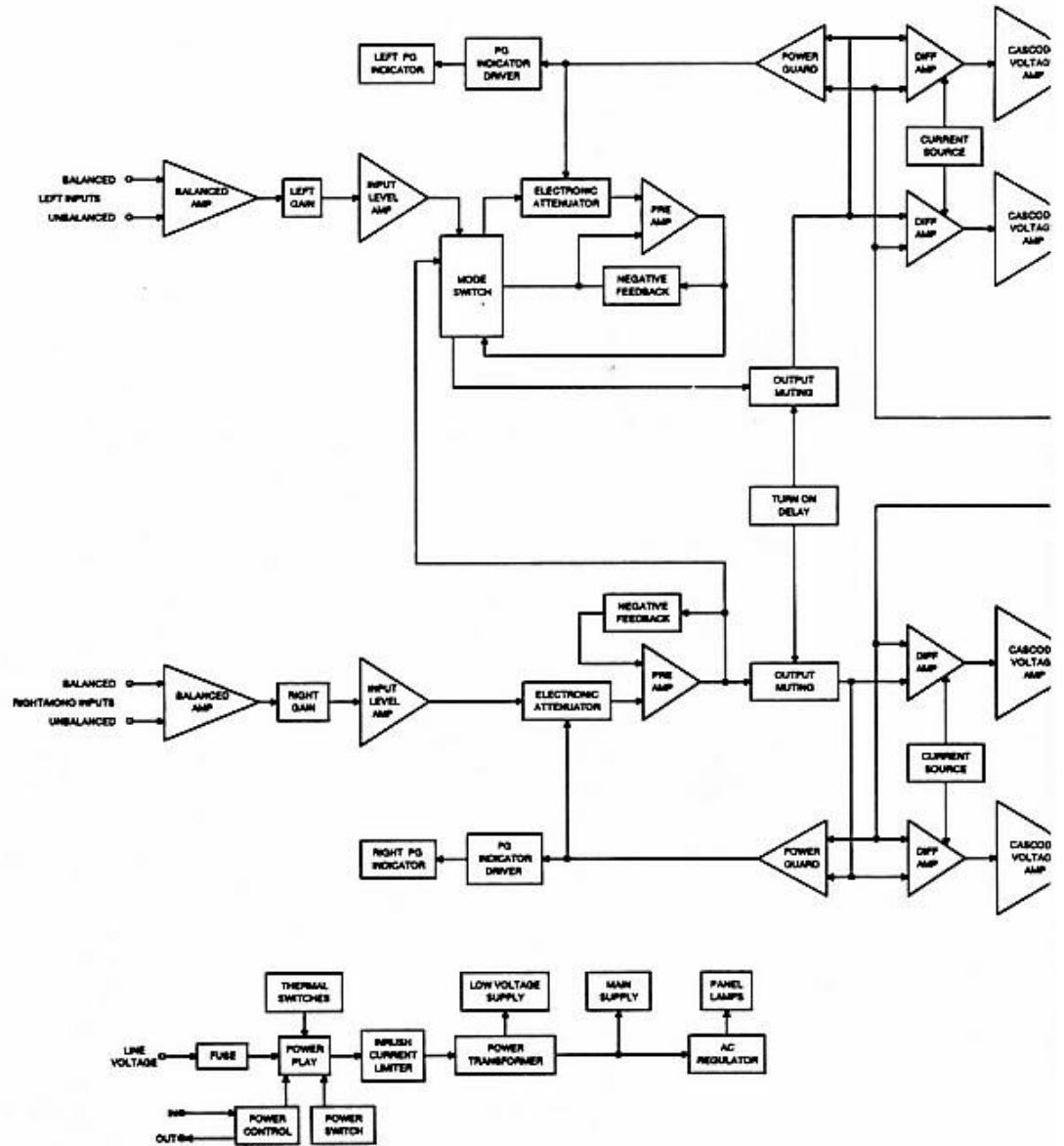
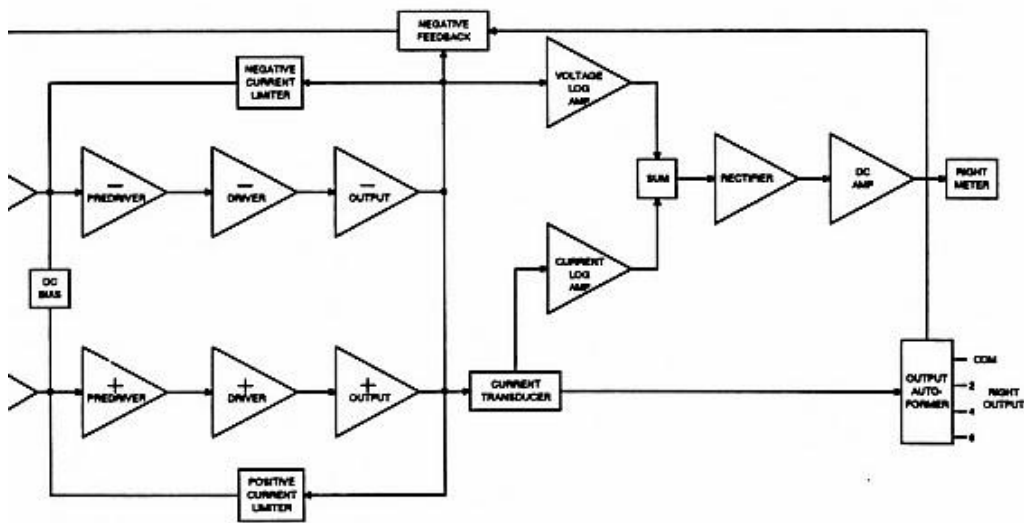
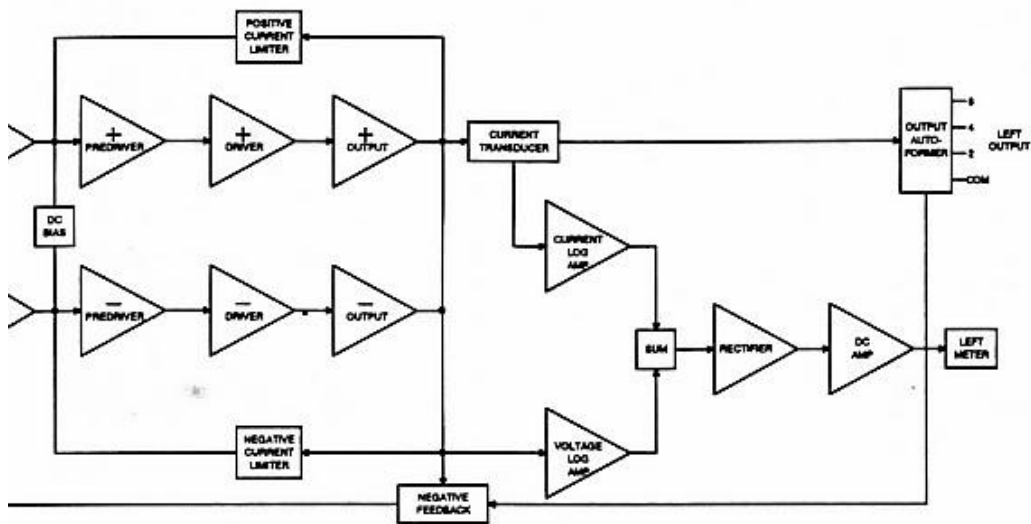

Fig. 2 - Top view with cover removed

Block Diagram





1 Interconnection Diagram

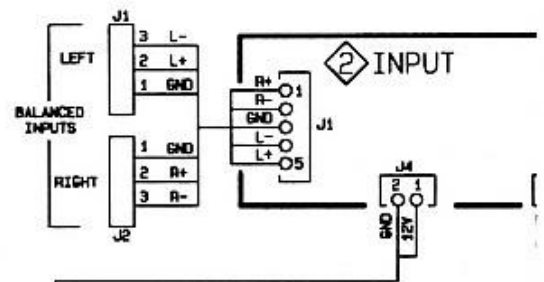

INTERCONNECTION PARTS LIST

Symbol	Part	Description
INTERCONNECTION		
C1	052005	Capacitor Assy
DIODES		
D1	070139	BRID, RECT, GBPC3504
FUSES		
F1	089061	Fuse, 6.25A, 240V S.B.
F1 (EXPORT VERSION)	089062	Fuse, 3.2A, 240V S.B.
SWITCHES		
S1,S4	146237	Power Switch
S2,S3	153017	Thermal Switch
THERMISTORS		
RT1,RT2	052008	Thermistor, 5 ohm
TRANSFORMER		
T1	048491	Power
T2(L&R)	047142	Audio

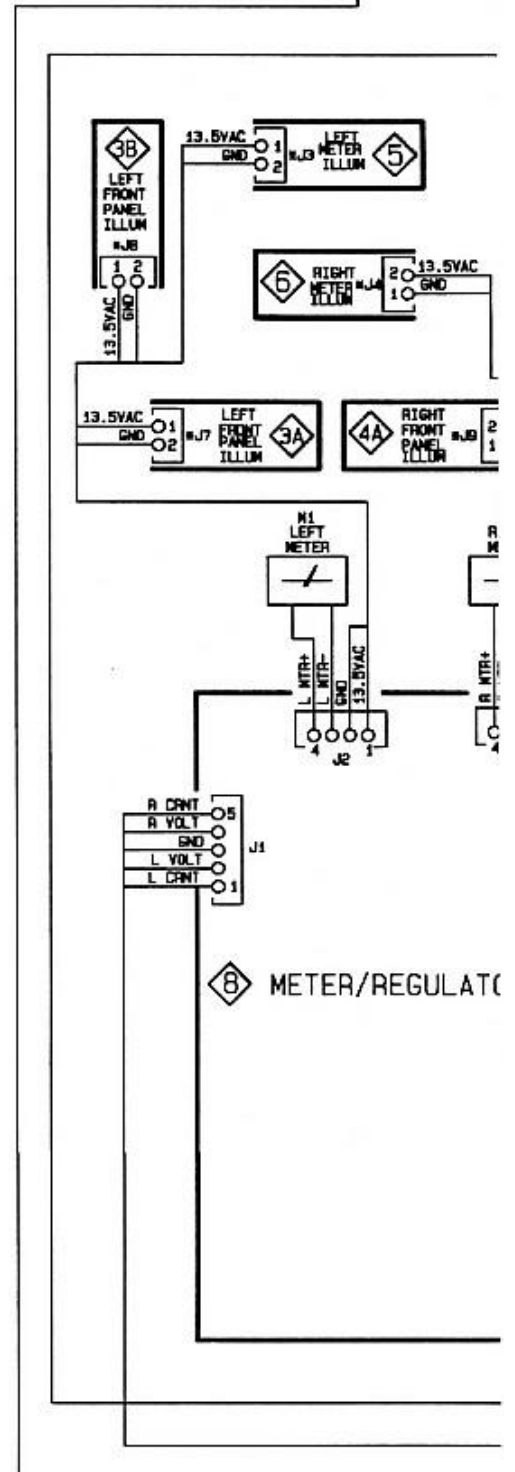

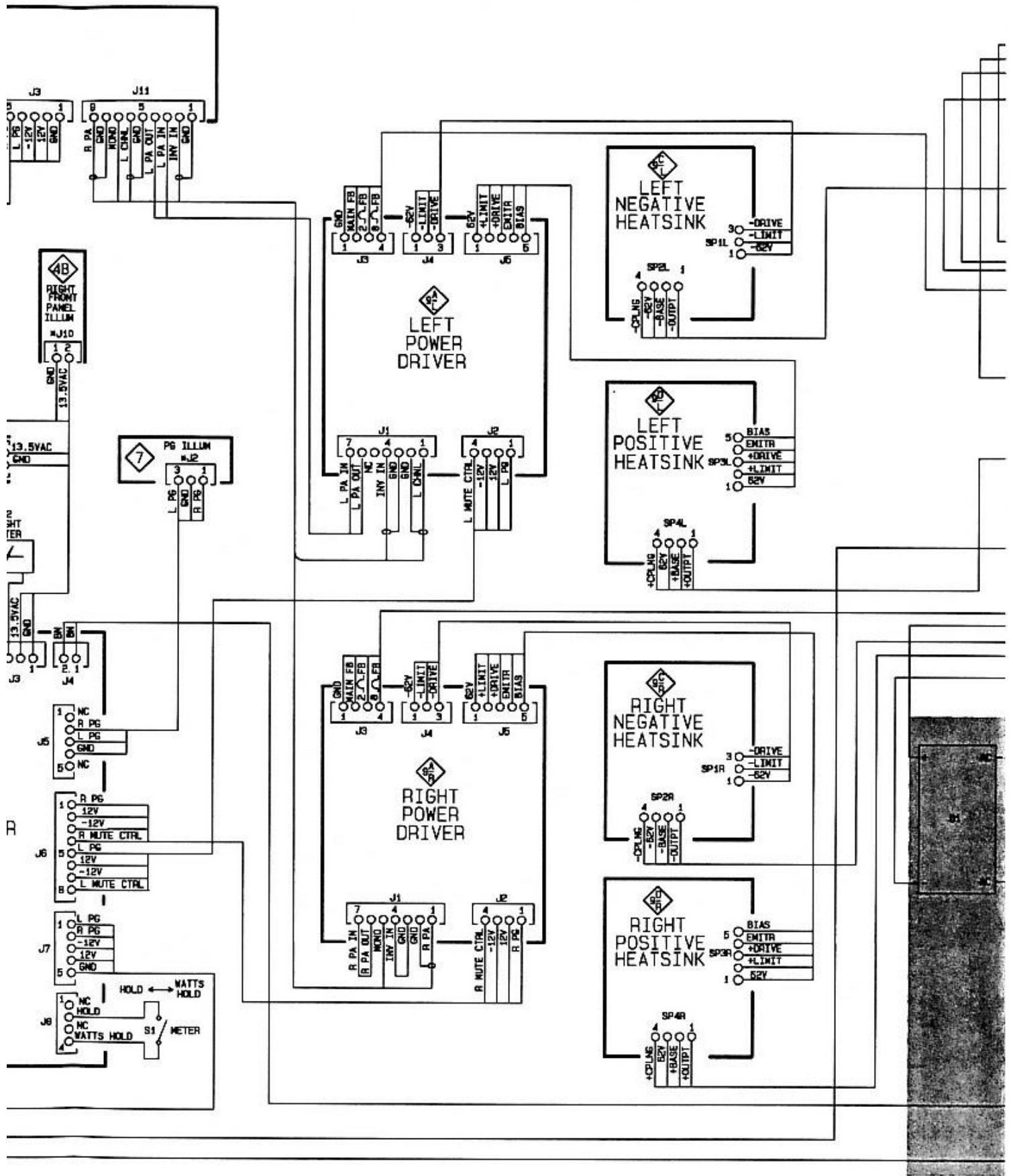

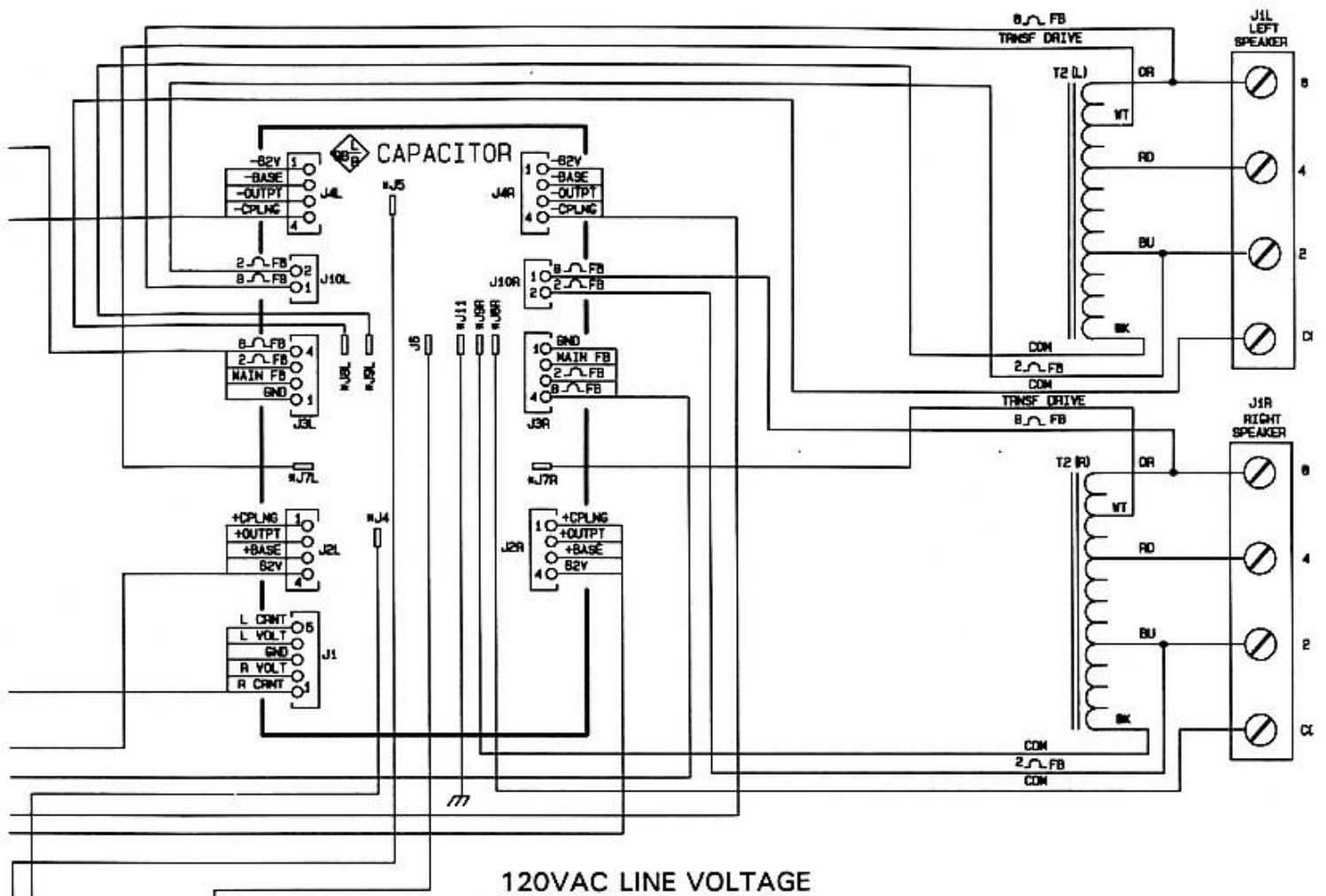

120VAC LINE VOLTAGE

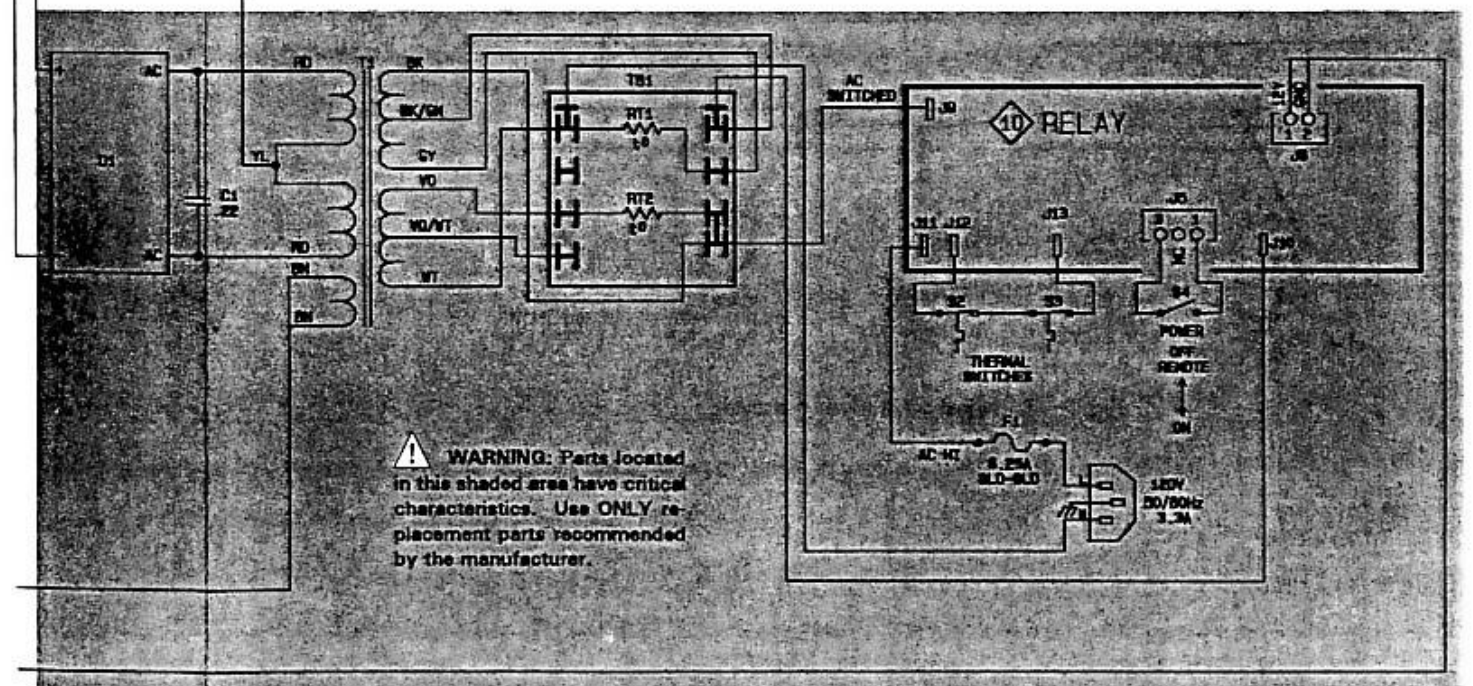

1

230VAC LINE VOLTAGE

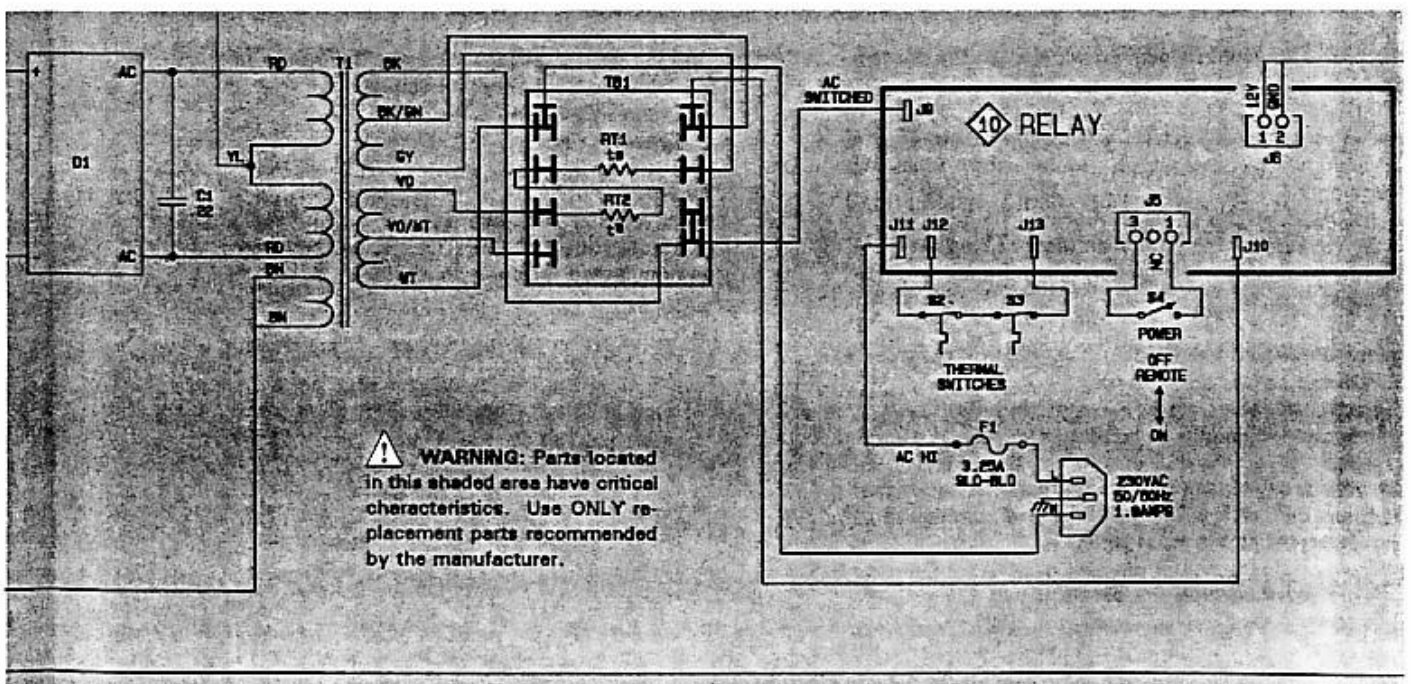

Input 2

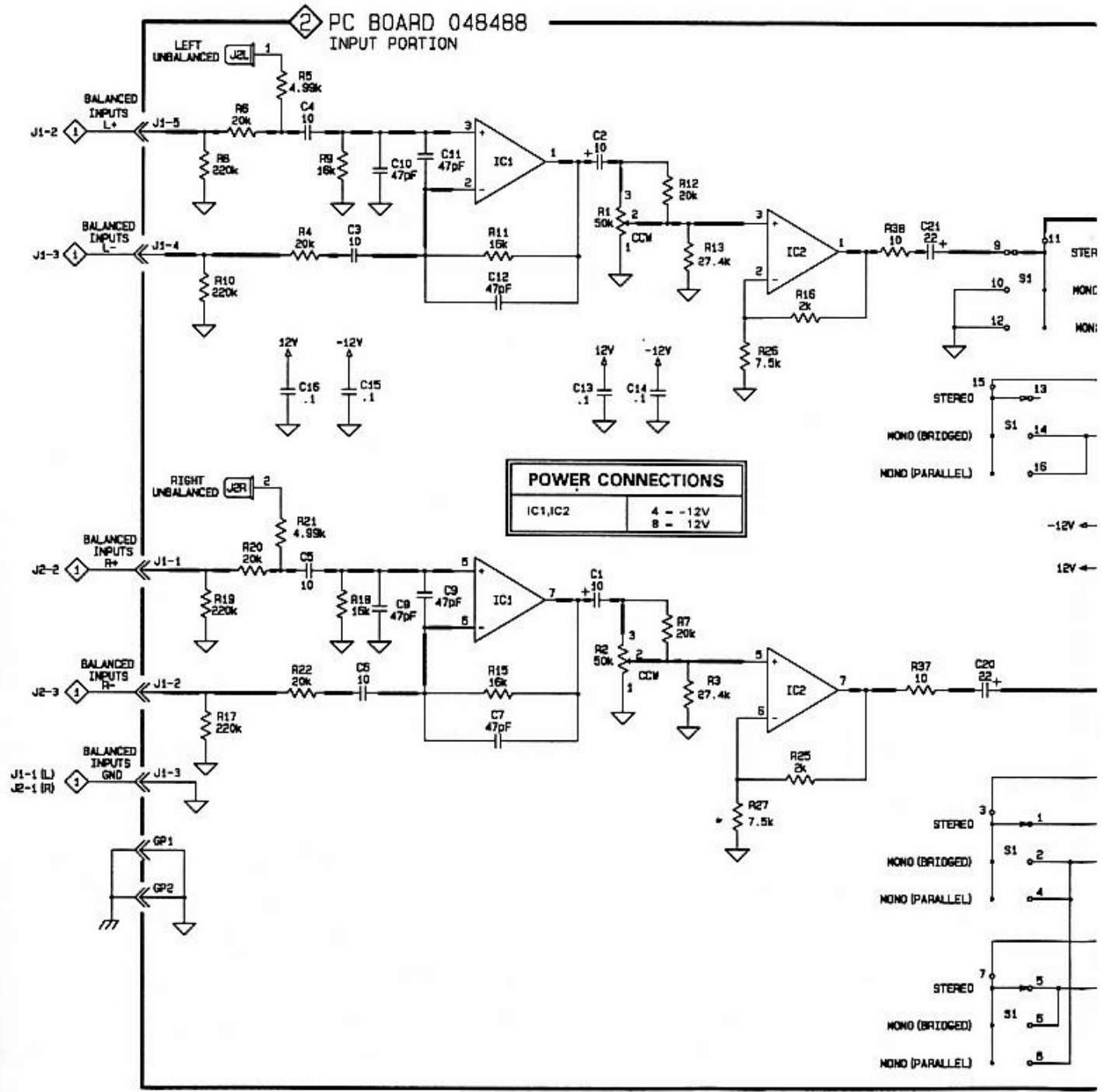

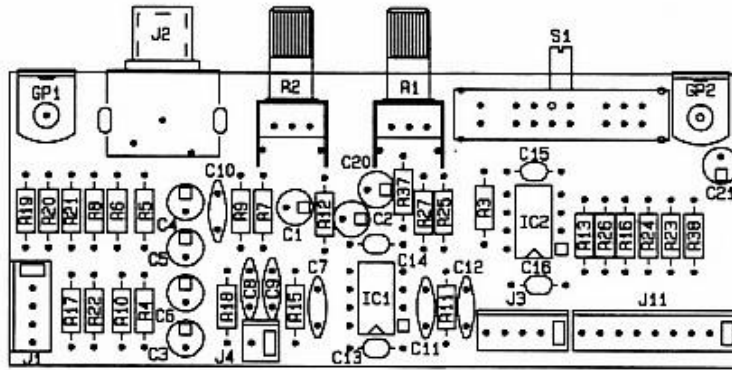
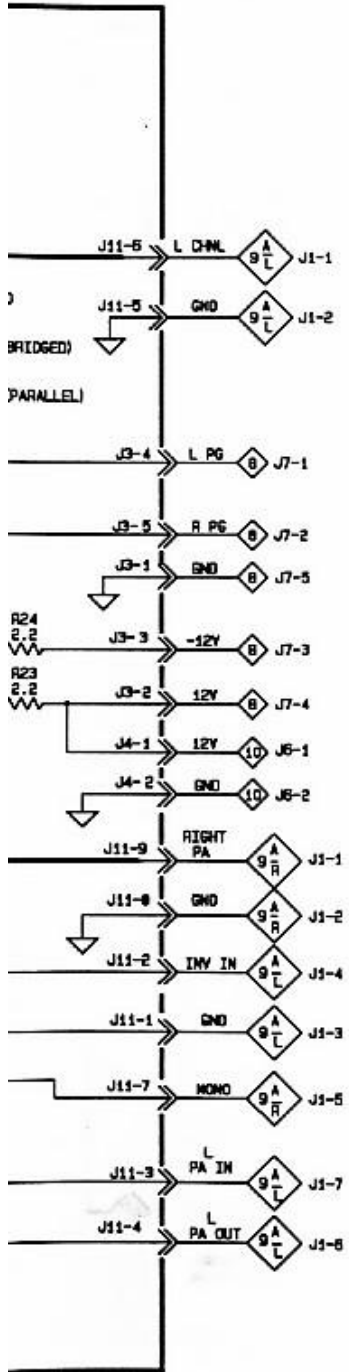

INPUT PORTION OF
PCB 048488

**INPUT
PARTS LIST**

Symbol	Part	Description
INTEGRATED CIRCUITS		
IC1, IC2	133094	Dual Op Amp, NE5532N
SWITCHES		
S1	148069	MODE

3 Left Front Panel Illumination

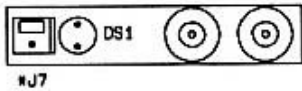
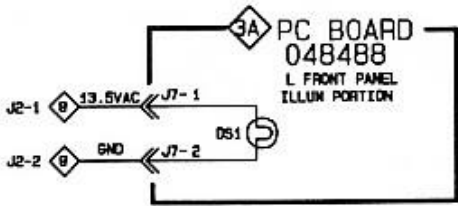

FRONT PANEL ILLUMINATION PORTION OF PCB 048488

COMPONENTS MARKED WITH AN ASTERISK (*) ARE ON REVERSE SIDE OF BOARD

LEFT FRONT PANEL ILLUMINATION PARTS LIST

Symbol	Part	Description
LIGHTING DEVICES		
DS1	058120	INC, 14V, 7373

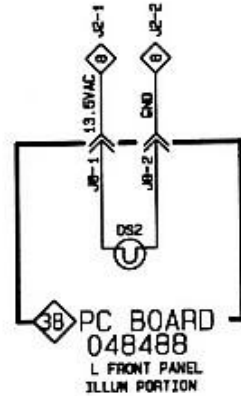
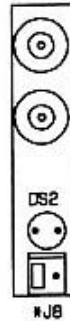

LEFT FRONT PANEL ILLUMINATION PARTS LIST

Symbol	Part	Description
LIGHTING DEVICES		
DS2	058120	INC, 14V, 7373

4 Right Front Panel Illumination

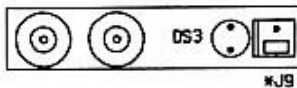
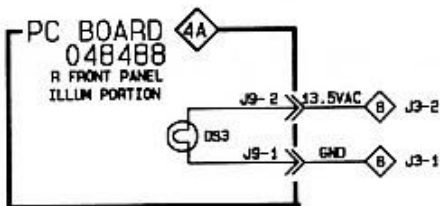

FRONT PANEL ILLUMINATION PORTION OF PCB 048488

COMPONENTS MARKED WITH AN ASTERISK (*) ARE ON REVERSE SIDE OF BOARD

RIGHT FRONT PANEL ILLUMINATION PARTS LIST

Symbol	Part	Description
LIGHTING DEVICES		
DS3	058120	INC, 14V, 7373

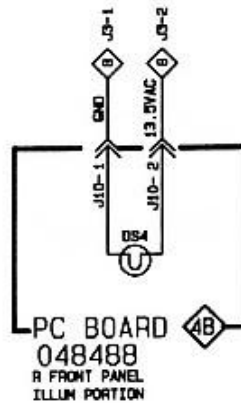
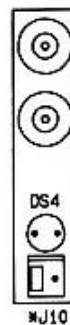

RIGHT FRONT PANEL ILLUMINATION PARTS LIST

Symbol	Part	Description
LIGHTING DEVICES		
DS4	058120	INC, 14V, 7373

5 Left Meter Illumination

COMPONENTS MARKED WITH AN ASTERISK (*) ARE ON REVERSE SIDE OF BOARD

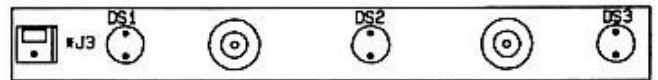
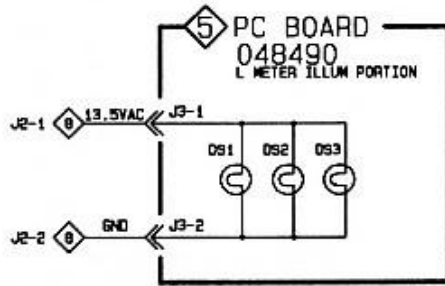

METER ILLUMINATION PORTION OF PCB 048090

LEFT METER ILLUMINATION PARTS LIST

Symbol	Part	Description
LIGHTING DEVICES		
DS1-DS3	058120	INC, 14V, 7373

6 Right Meter Illumination

COMPONENTS MARKED WITH AN ASTERISK (*) ARE ON REVERSE SIDE OF BOARD

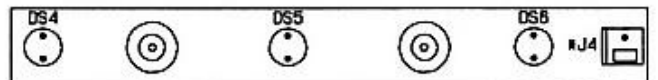
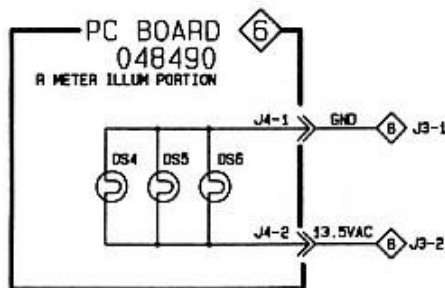

METER ILLUMINATION PORTION OF PCB 048090

RIGHT METER ILLUMINATION PARTS LIST

Symbol	Part	Description
LIGHTING DEVICES		
DS4-DS6	058120	INC, 14V, 7373

7 Power Guard Illumination

COMPONENTS MARKED WITH AN ASTERISK (*) ARE ON REVERSE SIDE OF BOARD

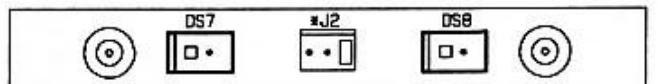
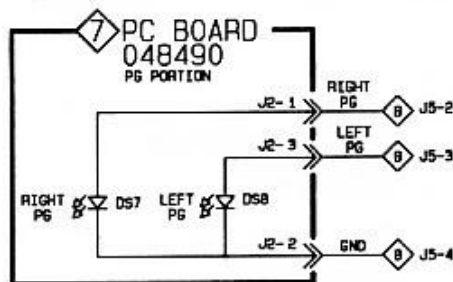

POWER GUARD PORTION OF PCB 048490

POWER GUARD ILLUMINATION PARTS LIST

Symbol	Part	Description
LIGHTING DEVICES		
DS7, DS8	058121	LED, Amber Bar, MV15-3101

Meter/Regulator

PC BOARD 048496

WARNING: Parts located in the below shaded areas have critical characteristics. Use ONLY replacement parts recommended by the manufacturer.

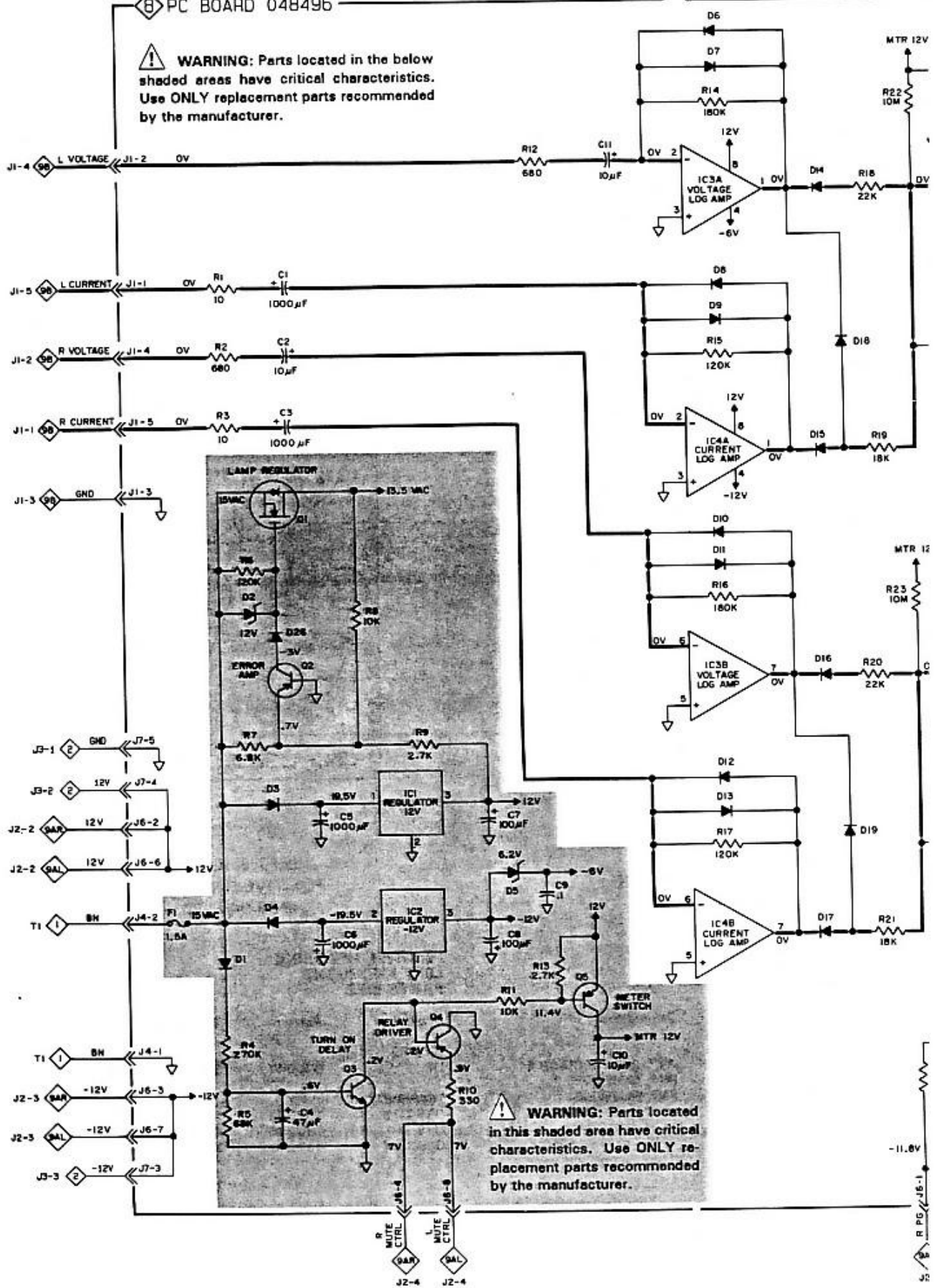

WARNING: Parts located in this shaded area have critical characteristics. Use ONLY replacement parts recommended by the manufacturer.

3

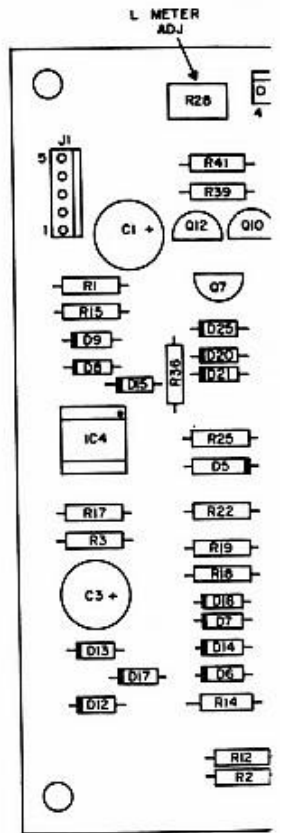
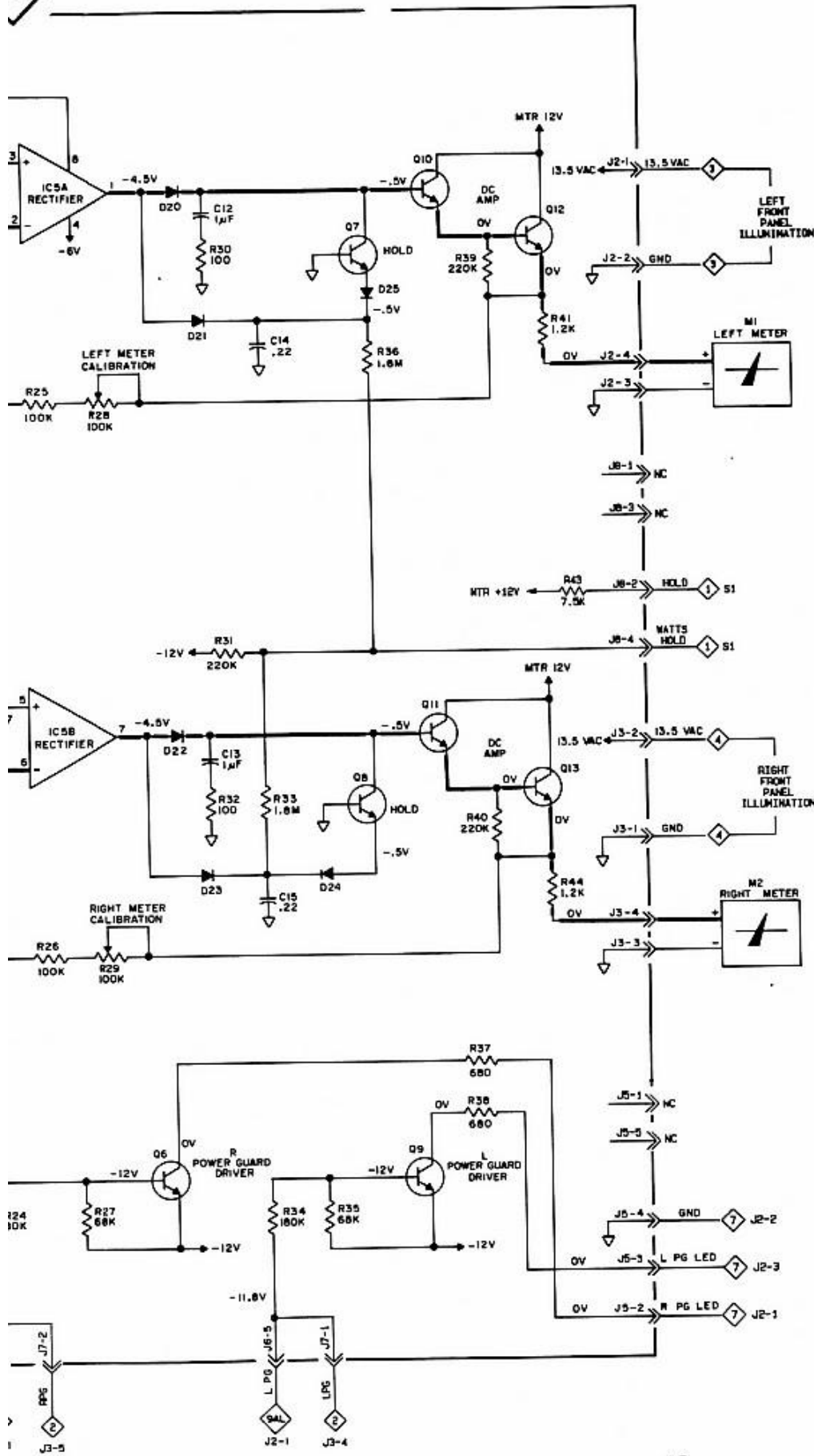

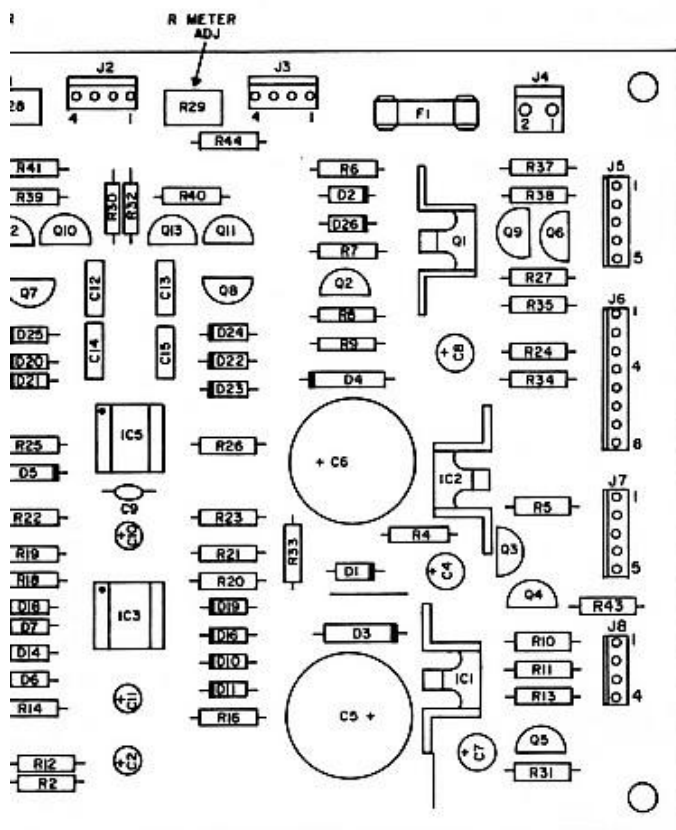

METER/REGULATOR
PCB 048496

METER/REGULATOR PARTS LIST

Symbol	Part	Description
DIODES		
D1	070047	SIG, 75V, 100mA, 1N4148
D2	070099	ZN, 12V, 5%, 500mW, 1N5242B
D3,D4	070131	RECT, 400V, 1A, 1N4004
D5	070085	ZN, 6.2V, 5%, 500mW, 1N5234B
D6-D22	070047	SIG, 75V, 150mA, 1N4148
FUSES		
F1	089052	Fuse, SB, 1.5A, 250V, 2AG
INTEGRATED CIRCUITS		
IC1	133156	+ 12V Regulator, MC78M12CT
IC2	133155	-12V Regulator, MC79M12CT
IC3,IC4	133028	Dual Hi-speed Operational Amp, MC4558CP1
IC5	133094	Dual Operational Amp, NE5532N
METERS		
M1,M2	124047	METER
TRANSISTORS		
Q1	132242	N, FET, BUZ71A
Q2	132224	PNP, MPS4126
Q3	132223	NPN, MPS4124
Q4,Q5	132224	PNP, MPS4126
Q6	132090	NPN, DAR, MPSA25
Q7,Q8	132223	NPN, MPS4124
Q9	132090	NPN, DAR, MPSA25
Q10-Q13	132254	NPN, 2SC2362KG

9

Amplifier

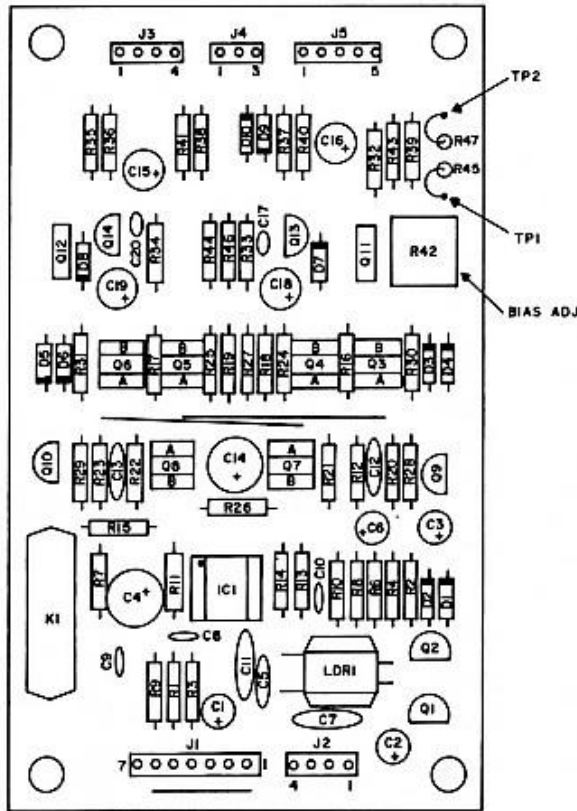

**LEFT & RIGHT
POWER DRIVER
PCB 048506**

POWER DRIVER LEFT AND RIGHT PARTS LIST

Symbol	Part	Description
DIODES		
D1-D10	070047	SIG, 75V, 150mA, 1N4148
INTEGRATED CIRCUITS		
IC1	133094	Dual Op Amp, NE5532N
RELAYS		
K1	087050	SPST, 5VDC, Reed, HE3321A0400
RESISTORS (LIGHT DEPENDENT)		
LDR1	144179	LDR, VTL5C9
TRANSISTORS		
Q1, Q2	132224	PNP, MPS4126
Q3	132253	PNP, Dual, 2SA1237G
Q4	132250	NPN, Dual, 2SC3066G
Q5	132251	PNP, Dual, 2SA1239G
Q6	132252	NPN, Dual, 2SC3064G
Q7	132250	NPN, Dual, 2SC3066G
Q8	132251	PNP, Dual, 2SA1239G
Q9	132136	NPN, MPSA42
Q10	132147	PNP, MPSA92
Q11	132249	PNP, 2SA1480D or 2SA1480E
Q12	132248	NPN, 2SC3790D or 2SC3790E
Q13	132223	NPN, MPS4124
Q14	132224	PNP, MPS4126

COMPONENTS MARKED WITH
AN ASTERISK (*) ARE ON
REVERSE SIDE OF BOARD

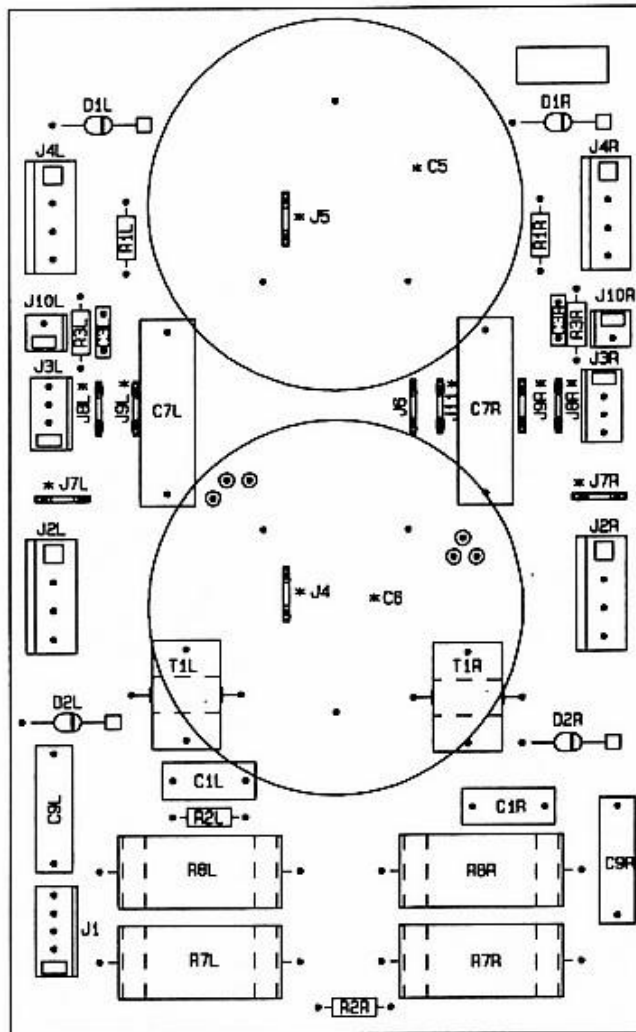

**CAPACITOR
PCB 048490**

**CAPACITOR BRD.
PARTS LIST**

<i>Symbol</i>	<i>Part</i>	<i>Description</i>
CAPACITORS		
C5,C6	066442	Capacitor Elect 57000uF/40V
DIODES		
D1,D2	070031	RECT, 400V, 1.5A
TRANSFORMERS		
T1	159215	Current

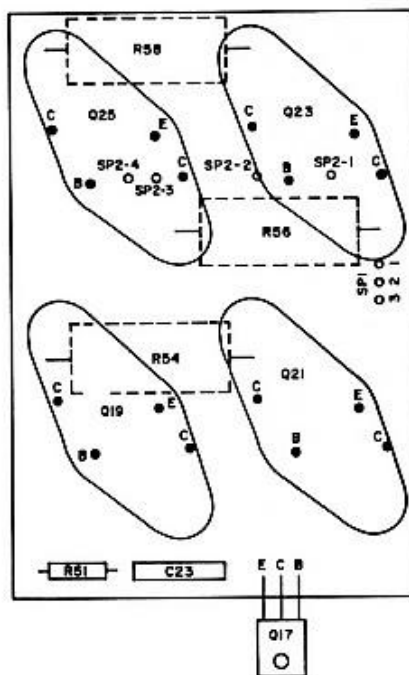

LEFT & RIGHT
NEGATIVE HEATSINK
PCB 047112

**NEGATIVE HEATSINK
LEFT AND RIGHT
PARTS LIST**

Symbol	Part	Description
TRANSISTORS		
Q17	132249	PNP, 2SA1480D OR E
Q19	132247	PNP, MJ15021
Q21, Q23, Q25	132213	PNP, MJ15025

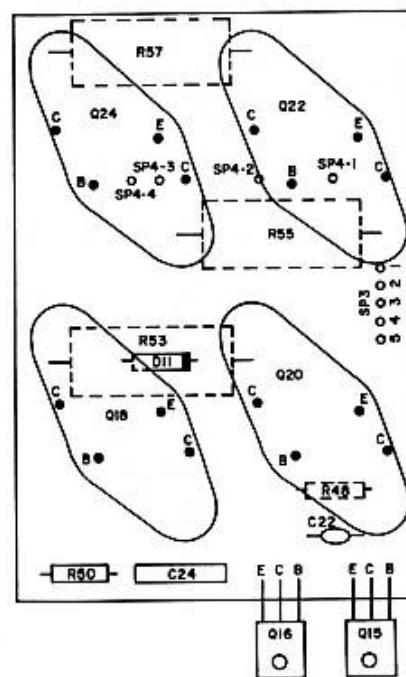

LEFT & RIGHT
POSITIVE HEATSINK
PCB 047110

**POSITIVE HEATSINK
LEFT AND RIGHT
PARTS LIST**

Symbol	Part	Description
DIODES		
D1	070047	SIG, 75V, 150mA, 1N4148
TRANSISTORS		
Q15, Q16	132248	NPN, 2SC3790D or E
Q18	132246	NPN, MJ15020
Q20, Q24	132212	NPN, MJ15024

Amplifier 9

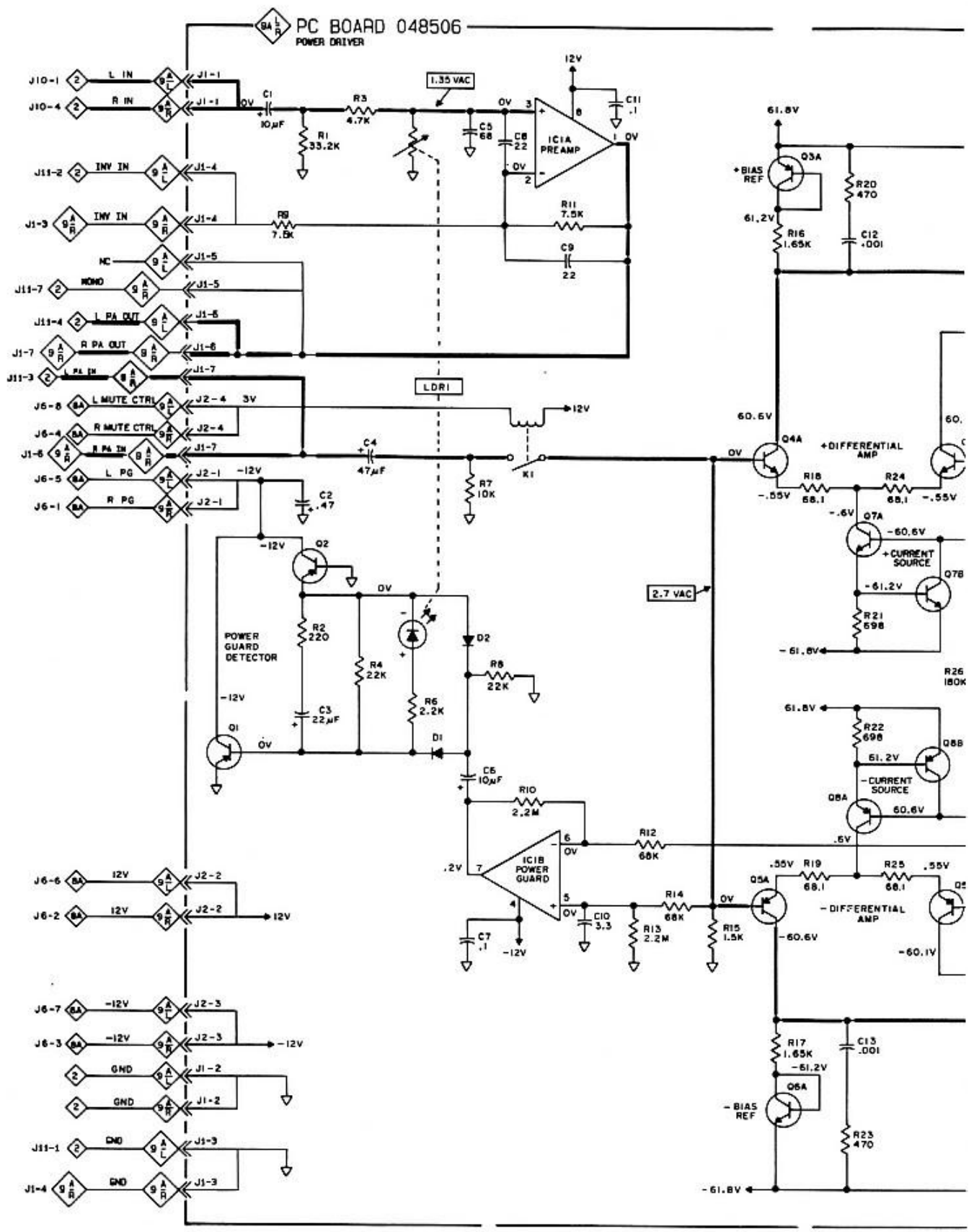

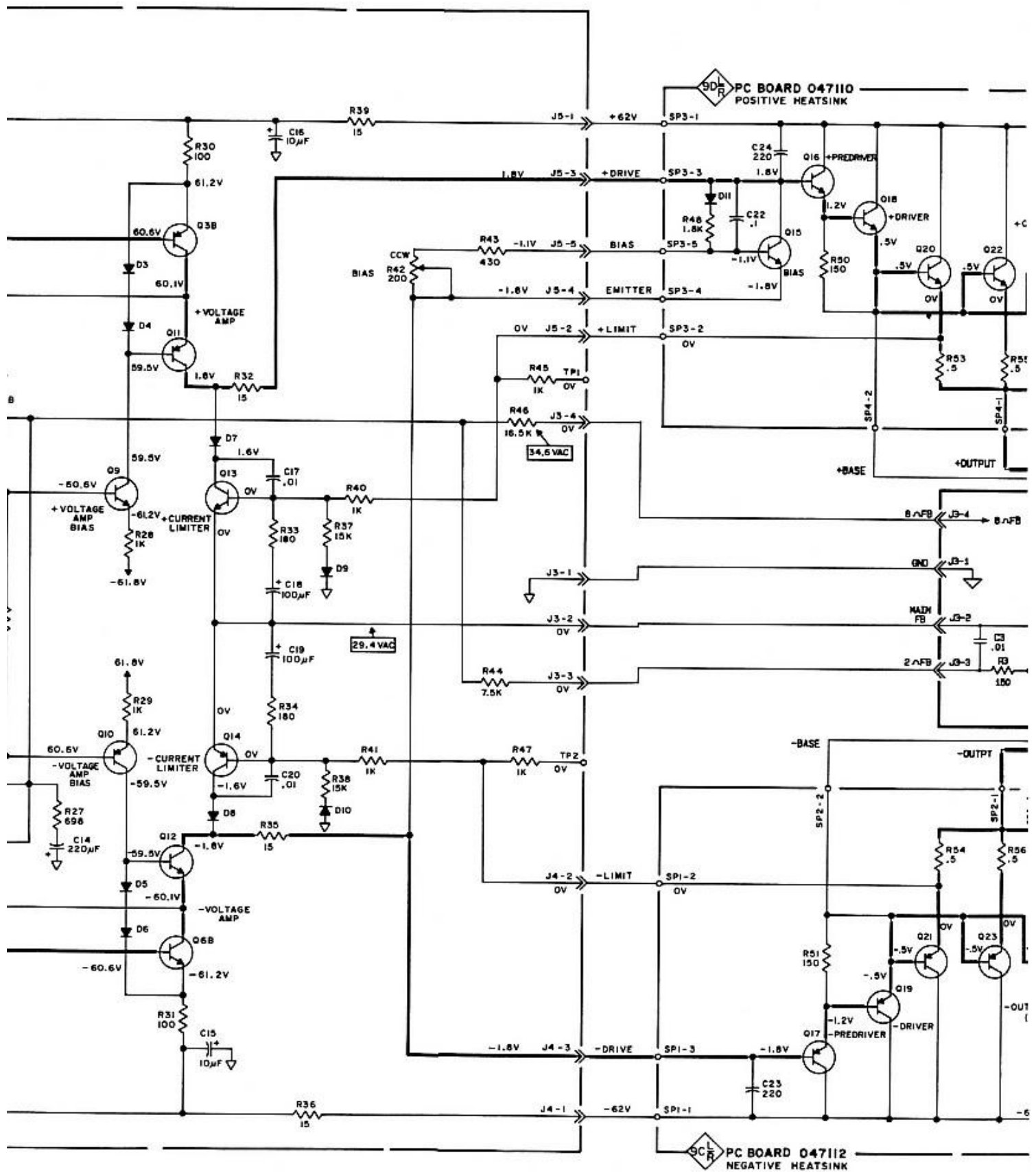

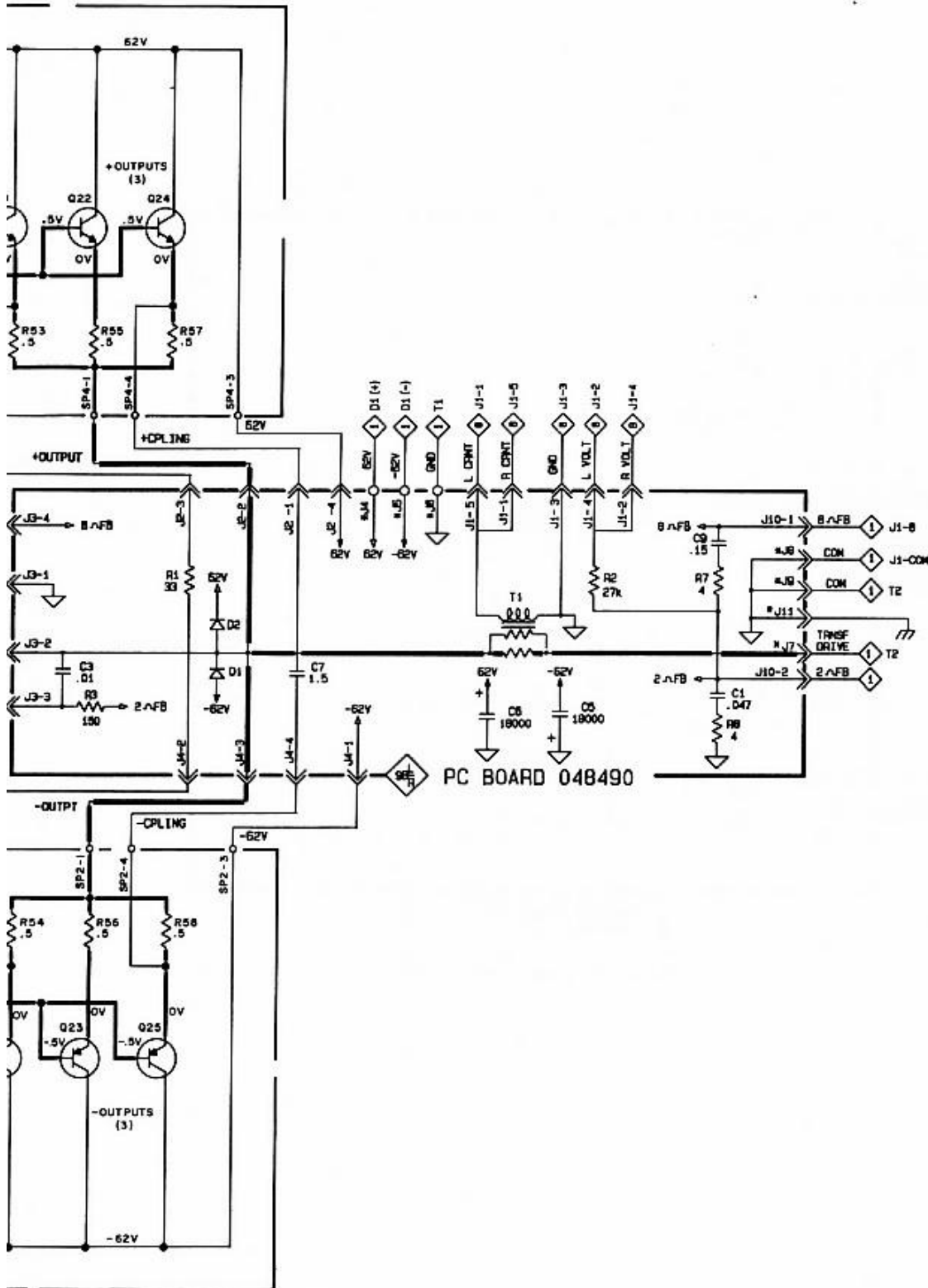

10 Relay

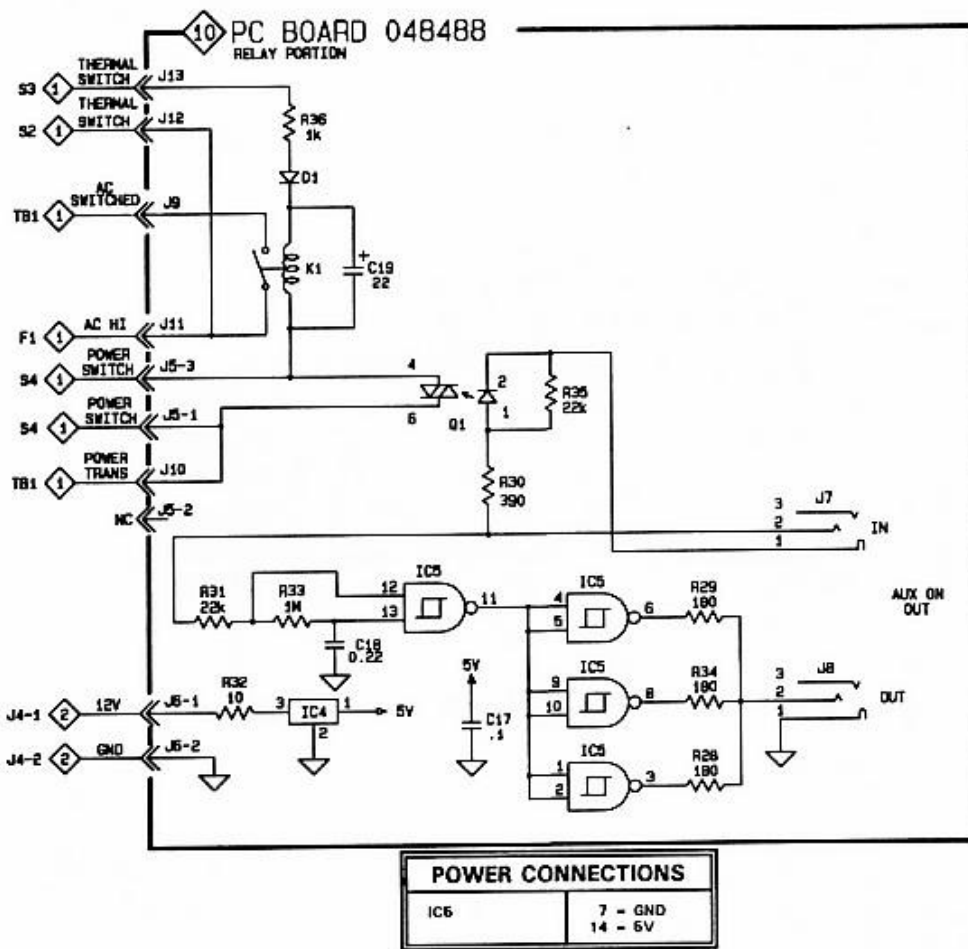

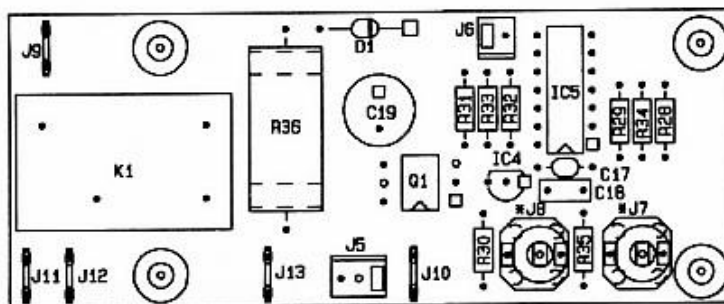

COMPONENTS MARKED WITH AN ASTERISK (*) ARE ON REVERSE SIDE OF BOARD

RELAY PORTION OF
PCB 048488

**RELAY
PARTS LIST**

<i>Symbol</i>	<i>Part</i>	<i>Description</i>
DIODES		
D1	070131	RECT, 400V, 1A, 1N4004
INTEGRATED CIRCUITS		
IC4	133093	5V Regulator, MC78L05ACP
IC5	133192	CMOS, Quad 2-Input NAND Gate, MC74HC132
RELAYS		
K1	087052	SPST, TV-8, 48VDC, JC1A-DC48V-TV
TRANSISTORS		
Q1	131020	OPTO ISO, MOC3023

Repacking Instructions

In the event it is necessary to repack the unit for shipment, the unit must be packed exactly as shown below.

IMPORTANT - The four plastic feet must be attached to the bottom of the unit so they will locate in the four holes of the bottom pad. Three #10 x 2-1/4" screws and washers must be used to fasten the unit securely to the bottom pad and wood skid. Failure to do this will result in shipping damage.

If a shipping carton or any of the interior parts is needed, please call or write the Customer Service Department of McIntosh Laboratory. Order parts from the accompanying list by part number.

Use the original shipping carton and interior parts only if they are in good serviceable condition.

Qty.	Part No.	Description
1	033838	Shipping carton only
2	033837	End cap (Foam pad)
1	033836	Inside carton only
1	033725	Top pad
1	033698	Bottom pad
3	017218	Plastic foot (spacer)
1	033699	Wood skid
3	101169	#10 x 2-1/4" Wood screw
3	104033	#10 x 1-3/4" Flat washer
4	017218	Plastic foot
4	100159	#10-32 x 3/4" Machine screw
4	104080	#10 x 7/16" Flat washer
1	048432	Shipping carton complete with all the above parts

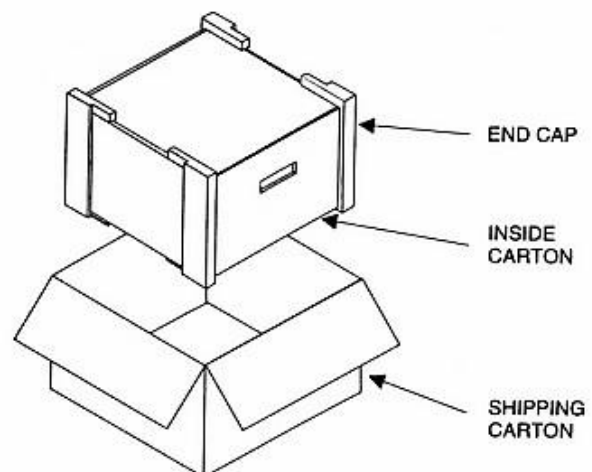
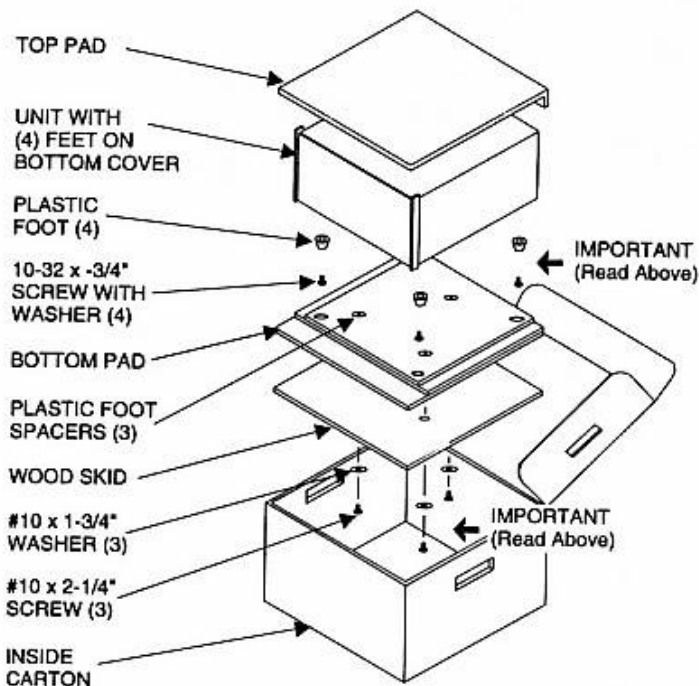

McIntosh

MC150 POWER AMPLIFIER

The continuous improvement of its products is the policy of McIntosh Laboratory Incorporated, who reserve the right to improve design without notice. Because of the constant upgrading of McIntosh products' circuitry and components, the Company cannot insure, and does not warrant, the accuracy of the within schematic material, which is intended for information only.

McIntosh Laboratory, Inc. 2 Chambers Street, Binghamton, NY 13903
Telephone (607) 723-3512 Printed in U.S.A. Part No. 040388